

SPECIFICATION SUBMITTAL SHEET



FEATURES

Sizes: 3/4" 1" 1 1/4" 1 1/2" 2"

Maximum working water pressure 175 PSI
 Maximum working water temperature 180°F
 Hydrostatic test pressure 350 PSI
 End connections Threaded ANSI B1.20.1

OPTIONS

(Suffixes can be combined)

- with full port QT union ball valves (standard)
- S - with bronze "Y" type strainer
- TCU - with test cocks "vertical" up
- Stainless steel ball valve handles

ACCESSORIES

- Repair kit (rubber only)
- Thermal expansion tank (Model WXTP)
- QT-SET Quick Test Fitting Set

APPLICATION

Designed for installation on potable water lines to protect against both backsiphonage and backpressure of polluted water into the potable water supply. Assembly shall provide protection where a potential health hazard does not exist. Supplied with union connections between shut-off valves and the device.

STANDARDS COMPLIANCE

(includes sizes 3/4", 1", 1 1/2", 2")

- ASSE® Listed 1015
- IAPMO® Listed
- AWWA Compliant
- CSA® Certified
- City of Los Angeles Approved
- Approved by the Foundation for Cross Connection Control and Hydraulic Research at the University of Southern California

MATERIALS

Main valve body Cast Bronze ASTM B 584
 Access covers Cast Bronze ASTM B 584
 Internals Stainless Steel, 300 Series
 Elastomers Silicone (FDA approved)
 Buna Nitrile (FDA approved)
 Polymers Noryl™, NSF Listed
 Springs Stainless steel, 300 series
 Ball valve handles Nickel plated carbon steel

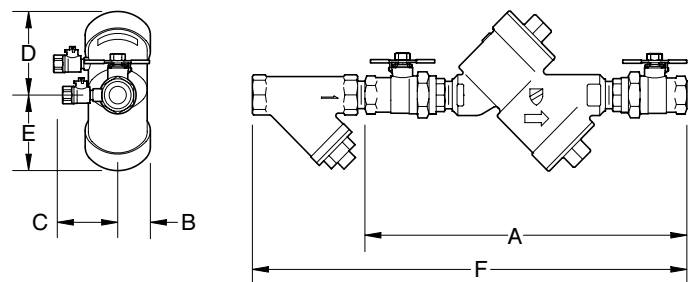

DIMENSIONS & WEIGHTS (do not include pkg.)

MODEL SIZE	DIMENSIONS (approximate)												WEIGHT				
	A		B		C		D		E		F		WITH BALL VALVES		LESS BALL VALVES		
	in.	mm	in.	mm	in.	mm	in.	mm	in.	mm	in.	mm	lbs.	kg	lbs.	kg	
1	20	12 1/2	318	1 1/2	38	3	76	3 1/2	89	3	76	16 1/4	413	9	4.1	5	2.3
3/4	25	13 3/4	349	1 1/2	38	3	76	3 1/2	89	3	76	18 1/2	470	9	4.1	8	3.6
1 1/4	32	18 1/2	470	2	51	3 1/2	89	4 1/2	114	4 1/2	114	23 1/2	597	21	9.5	16	7.3
1 1/2	40	19 1/8	486	2	51	3 1/2	89	4 1/2	114	4 1/2	114	24 3/4	629	24	10.9	16	7.3
2	50	20	508	2	51	3 1/2	89	4 1/2	114	4 1/2	114	26 15/16	684	27	12.3	16	7.3

FLOW CHARACTERISTICS
MODEL 950XLU 3/4", 1", 1 1/4", 1 1/2" & 2" (STANDARD & METRIC)

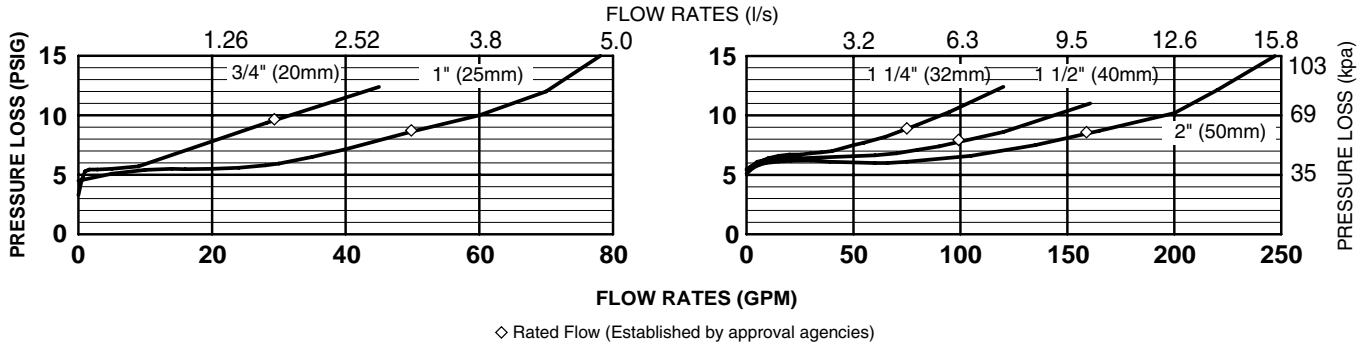

TYPICAL INSTALLATION

Local codes shall govern installation requirements. To be installed in accordance with the manufacturers' instructions and the latest edition of the Uniform Plumbing Code. Unless otherwise specified, the assembly shall be mounted at a minimum of 12" (305mm) and a maximum of 30" (762mm) above adequate drains with sufficient side clearance for testing and maintenance. The installation shall be made so that no part of the unit can be submerged.

Capacity thru Schedule 40 Pipe				
Pipe size	5 ft/sec	7.5 ft/sec	10 ft/sec	15 ft/sec
1/8"	1	1	2	3
1/4"	2	2	3	5
3/8"	3	4	6	9
1/2"	5	7	9	14
3/4"	8	12	17	25
1"	13	20	27	40
1 1/4"	23	35	47	70
1 1/2"	32	48	63	95
2"	52	78	105	167

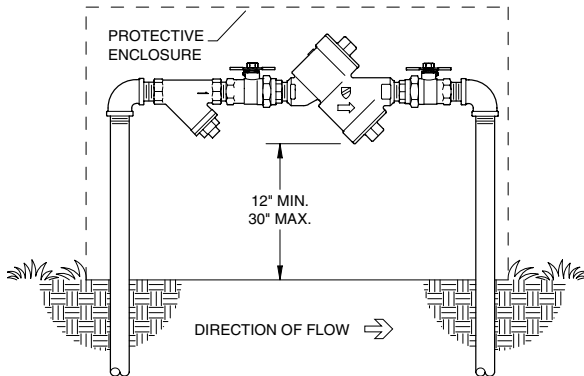

OUTDOOR INSTALLATION

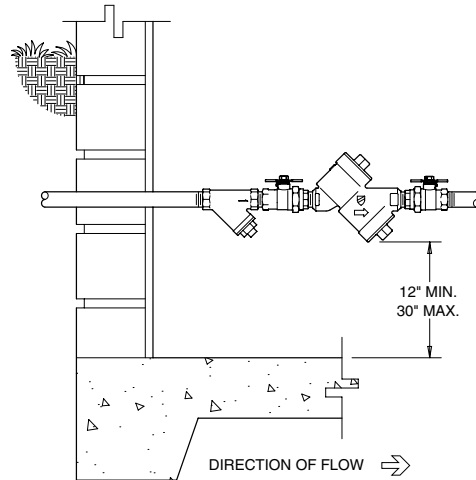

INDOOR INSTALLATION

SPECIFICATIONS

The Double Check Valve Assembly shall be ASSE® Listed 1015, and supplied with full port union ball valves. The main body and access covers shall be bronze (ASTM B 584), the seat rings and all internal polymers shall be NSF® Listed Noryl™ and the seat disc elastomers shall be silicone. The first and second checks shall be accessible for maintenance without removing the device from the line. The Double Check Valve Assembly shall be a WILKINS Model 950XLU.